



Street Lighting Feeder Pillar



Street Lighting Feeder Pillar (SLFP)

Street Lighting Feeder Pillar (SLFP)

Application

The Indkom Outdoor Street Lighting Feeder Pillar (SLFP) specifically covers the design and construction of an LV 100AMP, 3-way and 415V distribution system. It basically comprises of one unit of 100AMP rated NH-Type 3-pole fuse switch for the incoming and three units of 3 x 60AMP outgoing fuse links. Other components mounted within the metal enclosure include AC1-rated magnetic contactors and its ancillary control.

The Indkom SLFP is suitable for use in the tropical zone and hot climate with a maximum ambient temperature of 40°C and a mean annual temperature of 30°C, and is able to withstand heavy rainfall and a high humidity of up to 100%. It is designed for continuous operation in a 3-phase, 4-wires, 50Hz directly neutral earthed system.

For customized units, configurations can be designed to accommodate the client's specific requirements.

Design and Construction

The metal enclosure is made of a 2.00mm thick mild steel sheet. Epoxy polyester powder is used for a coated finishing.

The doors are lockable hinged-type with padlocking facilities, with 110 degrees opening access. The base is detachable, suitable for outdoor mounting. The enclosure is also provided with a watershed rooftop to prevent water from accumulating.

The degree of protection is IP44 in accordance to IEC 60529:1989-11 standard, i.e. protection against ingress of water and foreign object.



Type: SLFP-100



Inside wiring of the SLFP-100



Technical Specifications

Material Type	Mild steel with powder coating paint
Thickness (mm)	2mm
Rated Incoming Current	100A/200A
Rated Voltage	415/240V
Power Frequency Voltage 1 min	2500V
Frequency	50Hz
Rated Outgoing Current	3W/2W - 3 x 63A
Protection Degree	IP44
Dimension	1500mm (H) x 900mm (W) x 300mm(D)

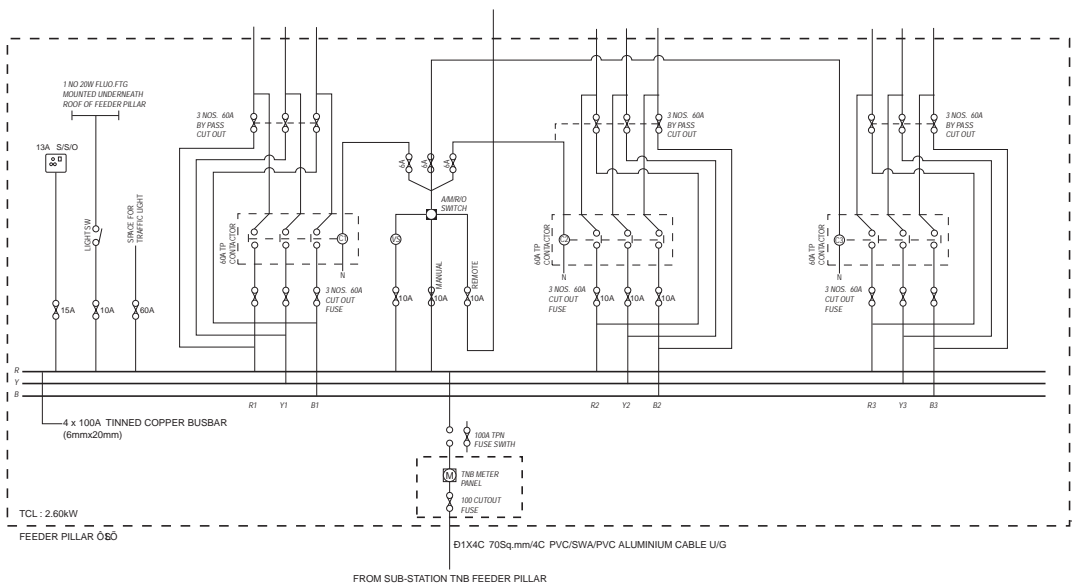
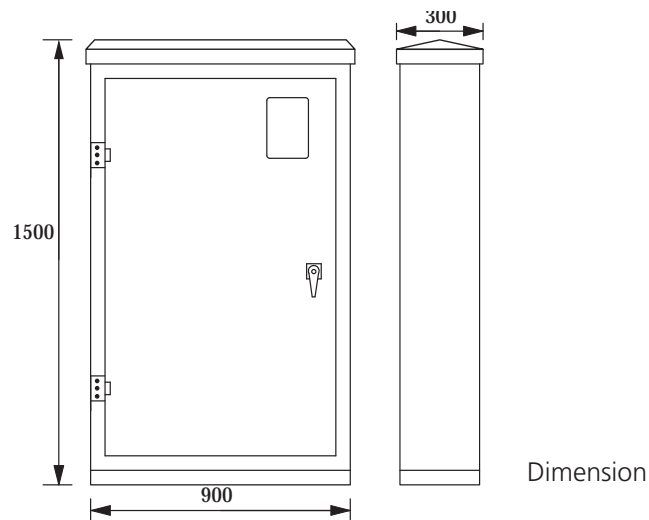

Schematic drawing

INDKOM Engineering Sdn Bhd

(company number: 128868-H)

Lot 1 & 3 Jalan Bawang Putih 24/34
Seksyen 24, 40300 Shah Alam
Selangor Darul Ehsan, Malaysia

phone: 603 5543 2388

fax: 603 5543 2377

e-mail: indeng@tm.net.my

web: www.indkom.com.my

(a member of the INDKOM Group of Companies)

As standards, applications and designs may change from time to time,
please contact us for the latest updates and technical information.

* QUALITY PRODUCTS *

* EXCELLENT SERVICES *

* COMPETITIVE PRICE *

* ON-TIME DELIVERY *